

## The FR-D700 Series

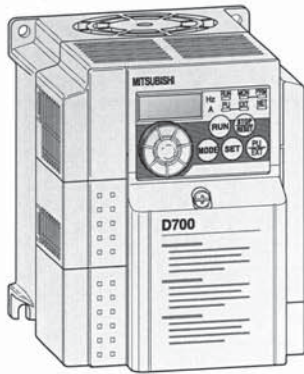

The FR-D700 is a pace-setter in the miniature drive system class. It features ultra-compact dimensions, simple and secure operation and a wide range of technology functions. The integrated jog shuttle control gives the user fast, direct access to all important drive parameters.

### Output range:

0.1–7.5 kW,  
200–240 V/380–480 V

### Available accessories:

Optional control units, versatile options and useful accessories are available for this frequency inverter.

Please refer to page 35 for details.

## Technical Details FR-D700

Product line		FR-D720S EC						FR-D740 EC								
		008	014	025	042	070	100	012	022	036	050	080	120	160		
Output	Rated motor capacity <sup>①</sup>	kW	0.1	0.2	0.4	0.75	1.5	2.2	0.4 (0.55)	0.75 (1.1)	1.5 (2.2)	2.2 (3)	3.7 (4)	5.5 (7.5)	7.5 (11)	
	Rated output capacity <sup>②</sup>	kVA	0.3	0.5	1.0	1.6	2.8	3.8	1.2	2.0	3.0	4.6	7.2	9.1	13.0	
	Rated current <sup>③</sup>	A	0.8	1.4	2.5	4.2	7.0	10.0	1.2 (1.4)	2.2 (2.6)	3.6 (4.3)	5.0 (6.0)	8.0 (9.6)	12.0 (14.4)	16.0 (19.2)	
	Overload capacity <sup>④</sup>	150 % of rated motor capacity for 60 s; 200 % for 0.5 s														
	Voltage <sup>⑤</sup>	3-phase, 0 V up to power supply voltage														
Input	Power supply voltage	1-phase, 200–240 V AC, -15 %/+10 %						3-phase, 380–480 V AC, -15 %/+10 %								
	Voltage range	170–264 V AC at 50/60 Hz						325–528 V AC at 50/60 Hz								
	Frequency range	50/60 Hz ± 5 %														
	Rated input capacity <sup>⑥</sup>	kVA	0.5	0.9	1.5	2.3	4.0	5.2	1.5	2.5	4.5	5.5	9.5	12	17	
Control	Control method	V/f control, optimum excitation control or general-purpose magnetic flux vector control														
	Modulation control	Sine evaluated PWM, Soft PWM														
	PWM switching frequency	0.7–14.5 kHz, user adjustable														
	Frequency range	Hz	0.2–400													
	Frequency resolution	Analog	0.06 Hz/0–50 Hz (terminal 2, 4: 0–10 V/10 Bit) 0.12 Hz/0–50 Hz (terminal 2, 4: 0–5 V/9 Bit) 0.06 Hz/0–50 Hz (terminal 4: 0–20 mA/10 Bit)													
		Digital	0.01 Hz													
	Frequency precision	±1 % of max. output frequency (temperature range 25 °C ± 10 °C) during analog input; ±0.01 % of max. output frequency during digital input (set via Digital Dial)														
	Voltage/frequency characteristics	Base frequency adjustable from 0 to 400 Hz Constant torque/variable torque pattern can be selected														
	Possible starting torque	≥ 150 %/1 Hz (for vector control oder slip compensation)														
	Torque boost	Manual torque boost														
	Acceleration/deceleration time	0.1 to 3600 s (may be set individually for acceleration and deceleration)														
Acceleration/deceleration characteristics	Linear or S-pattern acceleration/deceleration mode selectable															
Braking torque	DC braking	Operating frequency: 0–120 Hz, operating time: 0–10 s, voltage: 0–30 % (externally adjustable)														
Current stall prevention operation level	Operation current level setting 0–200 %, user adjustable															
Motor protection	Electronic motor protection relay (rated current user adjustable)															

Remarks:

Explanation for ① to ⑥ see next page.

Product line			FR-D720S EC						FR-D740 EC						
			008	014	025	042	070	100	012	022	036	050	080	120	160
Control signals for operation	Frequency setting signal	Analog input	Terminal 2: 0–5 V DC, 0–10 V DC Terminal 4: 0–5 V DC, 0–10 V DC, 0/4–20 mA												
		Digital input	Entered from operation panel or parameter unit. Frequency setting increment is selectable.												
	Operation functions		Maximum/minimum frequency setting, frequency jump operation, external thermal relay input selection, automatic restart after instantaneous power failure operation, forward/reverse rotation prevention, remote setting, second function, multi-speed operation, regeneration avoidance, slip compensation, operation mode selection, offline auto tuning function, PID control, computer link operation (RS485), optimum excitation control, power failure stop, speed smoothing control, Modbus-RTU												
Control signals for operation	Input signals		Any of 5 signals can be selected using parameters 178 to 182 (input terminal function selection): multi-speed selection, remote setting, second function selection, terminal 4 input selection, JOG operation selection, PID control valid terminal, external thermal input, PU-external operation switchover, V/F switchover, output stop, start self-holding selection, traverse function selection, forward rotation, reverse rotation command, inverter reset, PU-NET operation switchover, external-NET operation switchover, command source switchover, inverter operation enable signal, and PU operation external interlock												
	Output signals	Operating status	Can be selected using parameters 190 and 192 (output terminal function selection): inverter operation, up-to-frequency, overload alarm, output frequency detection, regenerative brake prealarm, electronic thermal relay function prealarm, inverter operation ready, output current detection, zero current detection, PID lower limit, PID upper limit, PID forward/reverse rotation output, fan alarm, heatsink overheat pre-alarm, deceleration at an instantaneous power failure, PID control activated, PID output interruption, during retry, life alarm, fault output 3, current average value monitor, maintenance timer alarm, remote output, alarm output, fault output												
		Analog signal	0–10 V DC												
Display option	Displays on operation panel or parameter unit (FR-PU07)	Operating status	Output frequency, motor current (steady), output voltage, frequency setting, cumulative energization time, actual operation time, converter output voltage, regenerative brake duty, electronic thermal relay function load factor, output current peak value, converter output voltage peak value, motor load factor, PID set point, PID measured value, PID deviation, inverter I/O terminal monitor, output power, cumulative power, motor thermal load factor, inverter thermal load factor, PTC thermistor resistance.												
		Alarm display	Fault definition is displayed when the fault occurs and the past 8 fault definitions (output voltage/current/frequency/cumulative energization time right before the fault occurs) are stored.												
	Additional displays on parameter unit FR-PU07	Operating status	Not used												
		Interactive guidance	Interactive guide for operation and troubleshooting via help function												
Protection	Functions		Overcurrent during acceleration, overcurrent during constant speed, overcurrent during deceleration, overvoltage during acceleration, overvoltage during constant speed, overvoltage during deceleration, inverter protection thermal operation, motor protection thermal operation, heatsink overheat, input phase failure <sup>①</sup> , output side earth (ground) fault overcurrent at start <sup>②</sup> , output phase failure, external thermal relay operation <sup>③</sup> , PTC thermistor operation <sup>④</sup> , parameter error, PU disconnection, retry count excess <sup>⑤</sup> , CPU fault, brake transistor alarm, inrush resistance overheat, analog input error, stall prevention operation, output current detection value exceeded												
	Protective structure		IP 20												
Others	Cooling		Self-cooling			Fan cooling			Self-cooling			Fan cooling			
	Power loss	W	14	20	32	50	80	110	40	55	90	100	180	240	280
	Weight	kg	0.5	0.6	0.9	1.1	1.5	1.9	1.2	1.2	1.3	1.4	1.5	3.1	3.1
	Dimensions (W × H × D)	mm	68 × 128 × 80.5		68 × 128 × 142.5	68 × 128 × 162.5	108 × 128 × 155	108 × 128 × 145	108 × 128 × 129.5		108 × 128 × 135.5	108 × 128 × 155.5	108 × 128 × 165.5	220 × 150 × 155	
Order information		Order no.	214189	214190	214191	214192	214193	214194	212414	212415	212416	212417	212418	212419	212420

Remarks:

- ① The applied motor capacity indicated is the maximum capacity applicable for use of the Mitsubishi 4-pole standard motor. The motor capacity ratings in brackets are for ambient temperatures up to 40 °C.
- ② The specifications of the rated output capacity are related to a motor voltage of 440 V.
- ③ The rated output current in brackets are for ambient temperatures up to 40 °C.
- ④ The % value of the overload capacity indicated is the ratio of the overload current to the inverter's rated output current. For repeated duty, allow time for the inverter and motor to return to or below the temperatures under 100 % load.
- ⑤ The maximum output voltage does not exceed the power supply voltage. The maximum output voltage can be changed within the setting range. However, the pulse voltage value of the inverter output side voltage remains unchanged at about  $\sqrt{2}$  that of the power supply.
- ⑥ The power supply capacity varies with the value of the power supply side inverter impedance (including those of the input reactor and cables).
- ⑦ This protective function is available with the three-phase power input specification model only.
- ⑧ This protective function does not function in the initial status.

Block Diagram FR-D700

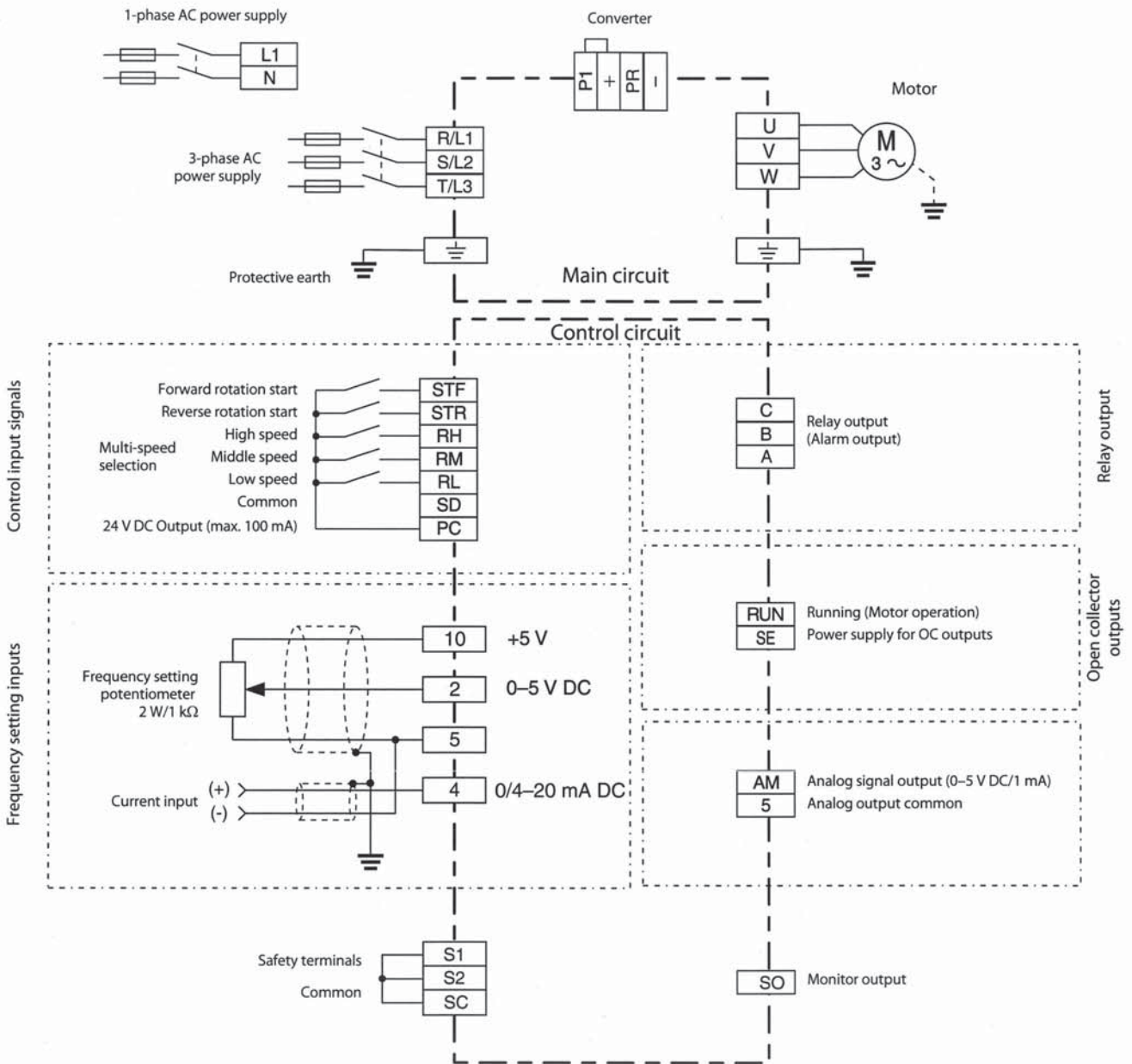

### Assignment of Signal Terminals

Function	Terminal	Designation	Description
Control connection	STF	Forward rotation start	The motor rotates forward, if a signal is applied to terminal STF. If the signals STF and STR are applied simultaneously, the STOP command is given.
	STR	Reverse rotation start	The motor rotates reverse, if a signal is applied to terminal STR. If the signals STF and STR are applied simultaneously, the STOP command is given.
	RH, RM, RL	Multi-speed selection	Preset of 15 different output frequencies; programmable.
Common	SD	Contact input common (sink) 24 V DC power supply common	A determined control function is activated, if the corresponding terminal is connected to the terminal SD (sink logic). The SD terminal is isolated from the digital circuits via optocouplers. When connecting the transistor output (open collector output), such as a programmable controller (PLC), connect the negative external power supply for transistor output to this terminal to prevent a malfunction caused by undesirable currents. When source logic has been selected, connect this terminal with 0 V of the external power supply.
	PC	Contact input common (source) 24 V DC power supply	24 V DC/0.1 A output In sink logic, when activated by open collector transistors (e.g. PLC) the positive pole of an external power supply has to be connected to the PC terminal. In source logic, the PC terminal serves as common reference point for the control inputs.
Setting value specification	10	Voltage output for potentiometer	Output voltage 5 V DC. Max. output current 10 mA Recommended potentiometer: 1 k $\Omega$ , 2 W linear (multi-turn potentiometer)
	2	Input for frequency setting value signal	The voltage setting value 0–5 (10) V is applied to this terminal. The voltage range is preset to 0–5 V. The input resistance is 10 k $\Omega$ $\pm$ 1k $\Omega$ . The maximum permitted voltage is 20 V DC.
	5	Reference point for frequency setting value signal	Terminal 5 is the reference point for all analog setting values and for the analog output signal AM. The terminal is isolated from the reference potential of the control circuit and should not be earthed for reasons of noise immunity.
	4	Input for current setting value signal	Inputting 4–20 mA DC (or 0–5 V, 0–10 V) provides the maximum output frequency at 20 mA and makes input and output proportional. This input signal is valid only when the AU signal is on (terminal 2 input is invalid). Use Pr. 267 to switch from among input 4 to 20 mA (initial setting), 0–5 V DC and 0–10 V DC. Set the voltage/current input switch in the "V" position to select voltage input (0–5 V/0–10 V).
Signal outputs	A, B, C	Relay output (alarm output)	The alarm is output via relay contacts (C-B = Normally Open, C-A = Normally Closed). The maximum contact load is 230 V AC/0.3 A or 30 V DC/0.3 A.
	RUN	Signal output for motor operation	Switched low (voltage of terminal SE is output) when the inverter output frequency is equal to or higher than the starting frequency (initial value 0.5 Hz). Switched high during stop or DC injection brake operation. (Low indicates that the open collector output transistor is on (conducts). High indicates that the transistor is off (does not conduct).) Permissible load 24 V DC (maximum 27 V DC)/0.1A (a voltage drop is 3.4 V maximum when the signal is on).
	SE	Reference potential for signal outputs	Reference potential for the signal RUN. This terminal is isolated from the reference potential of the control circuit 5 and SD.
	AM	Analog voltage output	Select one e.g. output frequency from monitor items. Not output during inverter reset. The output signal is proportional to the magnitude of the corresponding monitoring item. Output item (initial setting): Output frequency Output signal 0–10 V DC. Permissible load current 1 mA (load impedance 10 k $\Omega$ or more), resolution 8 bit
Interface	—	PU connector (RS485)	Communications via RS485
Manufacturer settings	S1, S2	Safety inputs	Keep these open. Otherwise, the inverter may be damaged.
	SC	Reference potential for safety inputs	Do not remove wires for shorting across terminal S1 and SC, across terminal S2 and SC. If one of these wires is removed, the inverter cannot be operated.
	S0	Safety monitor output	

### Assignment of Main Circuit Terminals

Function	Terminal	Designation	Description
Main circuit connection	L1, N	Power supply 1-phase	Connect to the commercial power supply.
	R/L1, S/L2, T/L3	Power supply 3-phase	Keep these terminals open when using the high power factor converter (FR-HC) or power regeneration common converter (FR-CV).
	+, -	External brake unit connection	Connect the brake unit (FR-BU2), power regeneration common converter (FR-CV) or high power factor converter (FR-HC).
	+, P1	DC reactor connection	An optional DC reactor can be connected to the terminals P1 and +. Before connecting the DC reactor, disconnect the jumper from terminals P1 and +.
	+, PR	External brake resistor connection	Connect a brake transistor (FR-ABR, MRS) across terminals + and PR. (The brake resistor can not be connected to the FR-D720S-008 and 014.)
	U, V, W	Motor connection	Voltage output of the inverter (3-phase, 0 V up to input voltage, 0.2–400 Hz)
		PE	Protective earth connection of inverter

# /// DIMENSIONS

## 4 DIMENSIONS

### FR-D720S-008-042

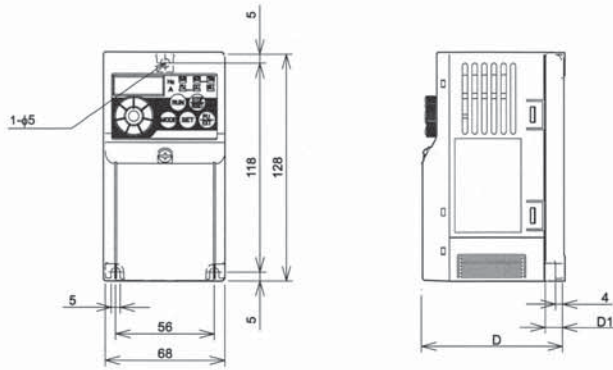

Type	D	D1
FR-D720S-008-014	80.5	10
FR-D720S-025	142.5	42
FR-D720S-042	162.5	62

All dimensions in mm

### FR-D720S-070/FR-D740-012-080

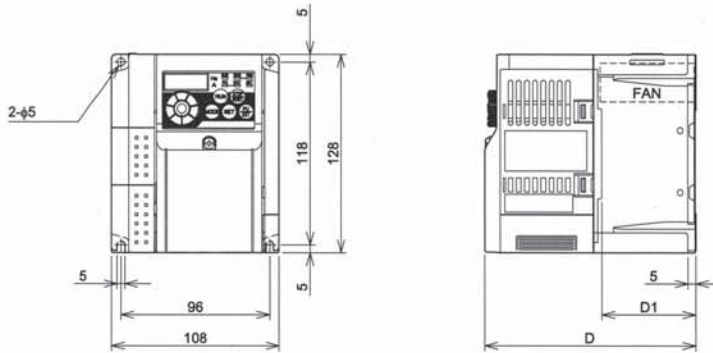

Type	D	D1
FR-D720S-070	155	60
FR-D740-012/022	129.5	54
FR-D740-036	135.5	
FR-D740-050	155.5	60
FR-D740-080	165.5	

All dimensions in mm

### FR-D720S-100

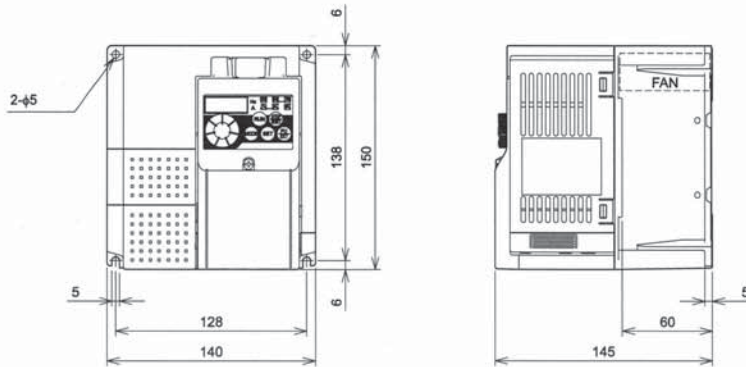

### FR-D740-120/160

