

# AVL-2000PLUS

## Auto Data Server

- Intel® Atom™ Z510 1.1GHz Processor
- Pre-installed Windows® XP Embedded
- Built-in HSUPA/GPRS/GSM, Wi-Fi® and Bluetooth®
- Built-in GPS with Dead Reckoning Support
- Built-in VGA Port Output and NTSC/PAL/SECAM Video Capture NTSC: 120fps@ D1  
PAL/SECAM: 100fps@ D1 for Display
- Optional UHF RFID Reader Module
- Supports On-Board Diagnostic (OBD)



## Advanced Vehicle Tracking/Monitoring with Auto Data Server

The AVL-2000PLUS comes integrated with a remote on-line and real time diagnostic system for vehicles via HSUPA/GPRS/GSM, Global Position System(GPS) and On-Board Diagnostic System(OBD) technologies. The compact design of the AVL-2000PLUS makes it easy to track goods or vehicles at any location and at anytime. The AVL-2000PLUS also provides video/audio capture and recording functions. Optional functions include UHF RFID Readers for a wide range of industrial and commercial applications, including supply chain management, asset tracking, authentication and access control. These complete advanced functions make an Auto Data Server suitable for accurate vehicle tracking, security monitoring, and data collection.



IEIMobile Introduction

Tablet PC

Industrial PDA (EDA)

Automotive PC

## Low Power Consumption and High Performance with Intel® Atom™ Z510 Processor

The AVL-2000PLUS features an Intel® Atom™ Z510 processor and Intel® System Controller Hub US15WP for embedded lifecycle support. The combination of high performance, low power consumption and integrated graphics/video makes this platform well suited for many embedded market segments such as in-vehicle infotainment, industrial control and automation, diagnostics and retail transaction solutions.

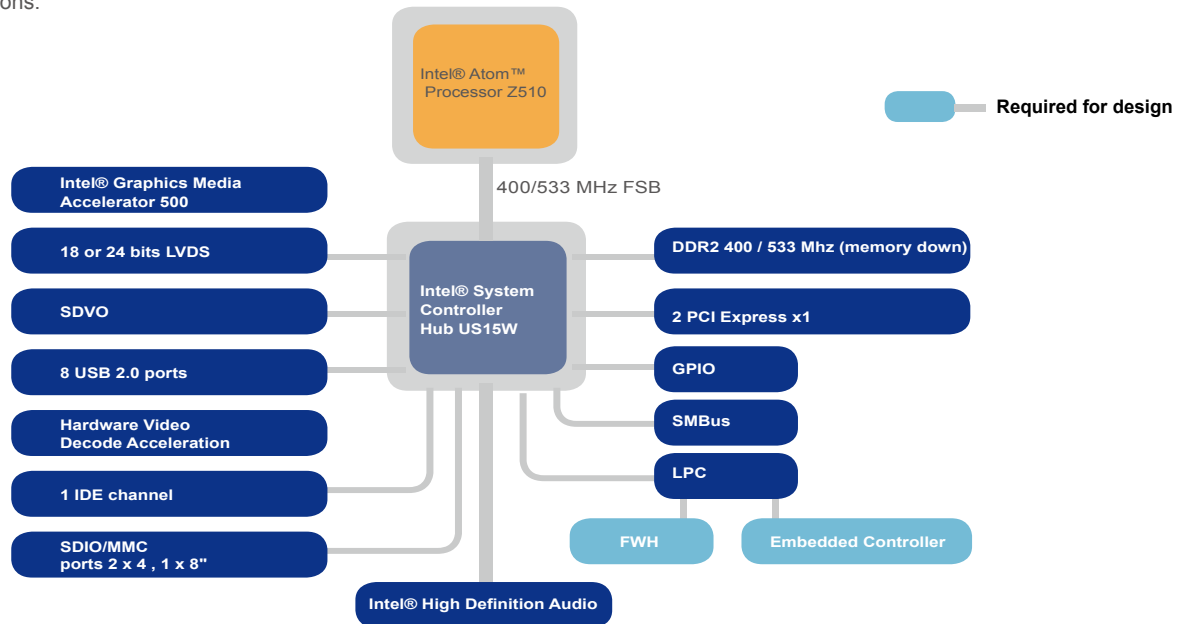

Supports Window XP operating systems in a componentized form allowing developers to create advanced commercial and consumer devices.

IEiMobile supports MeeGo. MeeGo is a combined effort between Intel, the world's largest chip manufacturer, and Nokia, the world's largest mobile handset manufacturer. It is a Linux-based open source platform designed from the ground up to provide cross-device support.

MeeGo API is based on Qt and Qt Mobility. Qt, a well established tool for developers, allows MeeGo to offer its unique advantage of portability and expandability.



## Wide Temperature Range and Compact, Rugged Design

- 30°C ~ 70°C Operating Temperature
- Shock and vibration protection ideal in vehicle environments



IEiMobile Introduction

Tablet PC

Industrial PDA (EDA)

Automotive PC

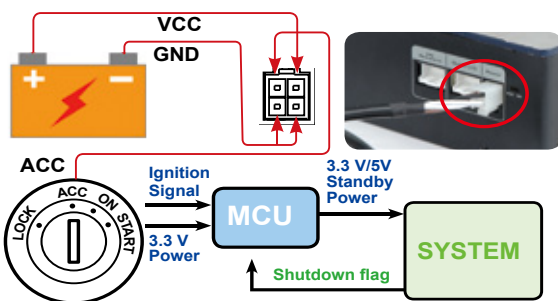

## Vehicle Power Management

- The unique MCU enables system to automatically reboot or shutdown based on the adjustable delay time by detecting ACC status.
- Surge protection and low power consumption hardware design

## One Key Recovery

Without having to go through complicated settings, IEi One Key Recovery uses exclusive technology to recover and backup your system with just one click.

Recover your system from

- Severe virus attack
- Operating system crash
- Man-made disasters



## Built-in Global Positioning System (GPS) with Dead Reckoning Support

Dead-Reckoning (DR) is a new feature implemented in some high-end automotive navigation systems in order to compensate for the limitations of GPS technology. The solution ensures uninterrupted navigation and tracking when satellite signals are blocked or unavailable, such as near tall buildings, mountains, canyons, in tunnels or in underground parking. With Dead Reckoning, the AVL-2000PLUS can still provides continuous position reporting even during GPS satellite blockage.



Armored Money Truck



Hazardous Material Handling



A built-in gyroscope is used to measure angular velocity. It provides highly accurate results when measuring an angular turn in any direction. The OBD-II, on the other hand, can accurately measure the speed of the vehicle. By combining gyroscopes with OBD-II, the AVL-2000PLUS is able to perform non-stop calculation of the dead reckoning position, orientation, and velocity (direction and speed of movement) of a moving object without any external references. It also eliminates the trouble and cost of a traditional speedometer cable installation. The AVL-2000PLUS is an ideal choice to enhance GPS performance and improve overall tracking ability.

AVL-2000PLUS uses standard OBD-II interface plug, allowing for quick and easy access to cruise data.

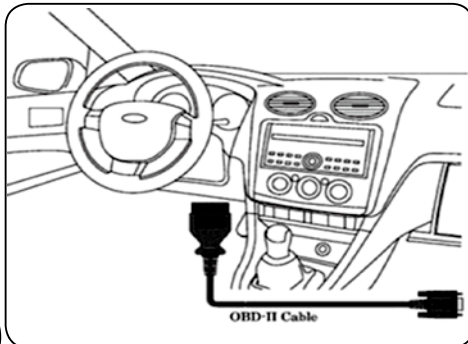

Simple "Plug-and-Play"

Traditional data retrieval via wired speedometer is cumbersome and time-consuming.

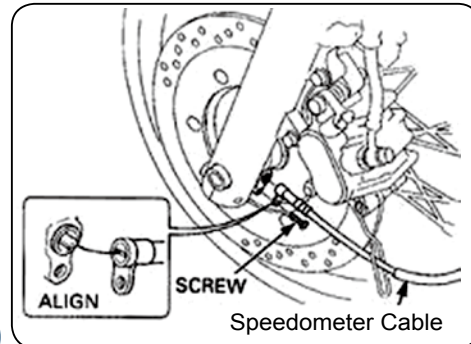

Hard to Install

## Leading the Wireless Revolution

### ■ WWAN 2.5G/3.5G/3.75G

Receive the localization coordinate of each vehicle through efficient mobile connectivity.

### Technology/Bands

- HSPA/HSPA/UMTS-800/850/900/1900/2100 MHz
- Quad-band EDGE/GPRS/GSM-850/900/1800/1900 MHz
- Dual-band EV-DO/CDMA-800/1900 MHz

### ■ Bluetooth® V2.0+EDR

- The Bluetooth module integrated in the AVL-2000PLUS transmits information between peripheral devices through the Bluetooth network and allows hands-free communications services. Efficient mobile connectivity for high quality video/audio streaming.

### ■ 802.11b/g Wi-Fi®

- Delivers broadband-speed browsing and connectivity, compared to traditional wired LAN connections. Best for near field or ad-hoc data communications.



## Extended Connectivity

### ■ Multi-channel Real Time Video and Audio Capture Applications

- On-board video surveillance made easy with the AVL-2000PLUS. With multi-channel real time video and audio capture capabilities, it's designed to meet the requirements of modern security systems, especially in the transportation industry. It reduces loss and damage to goods and assets and increases the safety of the drivers. The AVL-2000PLUS SDK contains a library of four active channels video demo program, allowing for quick and easy customization of audio/video preview and capture application.

### Key Features

- Internal 4-channel video decoder and audio ADC
- High quality proprietary fast video locking system for non-real-time application
- Supports 4-channel D1 video plus 1-channel audio simultaneously with independent channel control
- Dynamic synchronization: video processing; multiple video format output support Y422, Y420, IYUI/Y411, Y41P, RGB555 and RGB565
- Dual support for Direct Show and Direct Draw
- Accepts all NTSC(M/N/4.43) / PAL(B/D/G/H/I/ K/L/M/N/60) / SECAM standards with auto detection



## PC-Style Peripherals

- 3-in-1 RS-232/422/485 serial interface

The AVL-2000PLUS is an ideal choice for connecting RS-232/422/485 serial devices to an Ethernet network, making it possible for software to access serial devices anywhere on a local network.



- Full speed USB 2.0 host

Supports connection to USB devices such as standard HIDs (Human Interface Device) like keyboard and mouse, USB storage, USB card reader, or proprietary USB devices

- 10/100/1000 Mbps Ethernet LAN

Wherever Ethernet LAN is available, the AVL-2000PLUS LAN port provides another faster and more efficient networking option

## In-Vehicle Communication

●Almost all of the automobiles produced today are required by law-to provide an interface for the connection of diagnostic test equipment. The AVL-2000PLUS provides a connection to the vehicle's On-Board Diagnostics (OBD) port (OBD-II connector), and supports several popular data transfer protocols and standards



### Protocols and Standards

SAE J1850 PWM (41.6 kbaud)
SAE J1850 VPW (10.4 kbaud)
ISO 9141-2 (5 baud init)
ISO 14230-4 KWP (5 baud init)
ISO 14230-4 KWP (fast init)
ISO 15765-4 CAN (11 bit ID,500 kbaud)
ISO 15765-4 CAN (29 bit ID,500 kbaud)
ISO 15765-4 CAN (11 bit ID,250 kbaud)
ISO 15765-4 CAN (29 bit ID,250 kbaud)
SAE J1939 CAN (29 bit ID,250* kbaud)



OBD-II Connector



AVL-2000PLUS Connector

### Supported OBD-II Connector Pins

OBD-II Pin	VTT Pin	Description
1		Manufacturer discretion. GM: J2411 GMLAN/SWC/ Single-Wire CAN.
2		Bus positive Line of SAE-J1850 PWM and SAE-1850 VPW
3		Ford DCL(+) Argentina, Brazil (pre OBD-II) 1997-2000, Usa, Europe, etc. Chrysler CCD Bus(+)
4		Chassis ground
5		Signal ground
6		CAN high (ISO 15765-4 and SAE-J2284)
7		K line of ISO 9141-2 and ISO 14230-4
8		-
9		-
10		Bus negative Line of SAE-J1850 PWM only (not SAE-1850 VPW)
11		Ford DCL(-) Argentina, Brazil (pre OBD-II) 1997-2000, Usa, Europe, etc. Chrysler CCD Bus(-)
12		-
13		-
14		CAN low (ISO 15765-4 and SAE-J2284)
15		L line of ISO 9141-2 and ISO 14230-4
16		Battery voltage

●Besides traditional applications for diagnostic trouble code readers and automotive scan tools, emerging applications like Location-Based Services (LBS) and Fleet Management Systems (FMS) adopt OBD combined with GPS and telecommunication to realize remote real-time diagnostics.

## Built-in Sensors and I/O

■ The AVL-2000PLUS has digital I/O to provide advanced vehicle monitoring and control applications. For example:

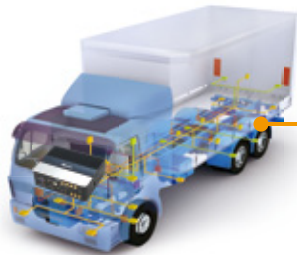

- Alarm, light and sound supplier which automatically checks for unusual tags.
- Sends security calls automatically when an unusual door-open is detected
- An automatic emergency call will be initiated when an airbag deployment is detected.

### Optional UHF RFID readers with antenna support

●The AVL-2000PLUS extends the benefits of 4-channel UHF RFID technology to in-vehicle applications via the long range UHF RFID readers which are ISO 18000-6C standard complaint and suitable for industrial warehouse management. It can be used in any harsh environment or temperature. It also supports error-free read performance in vehicles. The non line-of-sight tag reading is effectively used in item level identification, warehouse logistics, and security access management. The AVL-2000PLUS SDK contains libraries to read, write, lock and kill RFID tags, which can be easily integrated into software applications.

#### Key Features :

- High Gain, high performance
- Easy installation
- UV resistance
- IP65 waterproof and dustproof
- Pole mount & wall mount available



## Software Development Kits (SDK) and Built-in Software

### IEI AVL-2000PLUS SDK

Allows third-parties to develop software to send requests to the protocol firmware to acquire vehicle data

- Detects function key status (F1~F3) to program user interface application
- Implements digital I/O  
Offers an easy-to-use 8-bit digital I/O(4 inputs/4 outputs) configuration. Allows you to set digital outputs and read digital inputs.

- Multi-channel video capture card provides:  
Four active channels video settings  
Captured video preview  
Frame rate information  
Image property settings  
Fast configuration and ready-to-run  
Complete source code



● Channel Video Capture Card

- UHF module provides:  
A selection of 4 active antennas.  
Antenna in use identification  
Interface to read/write/lock/kill tag and retrieve product information such as product names, inventory, place of production, specification and read count information.

- OBD-II provides:  
Demo the query results of OBD-II interface with CAN protocol data. There are 4 types of CAN data supported. Also features an interface for users to acquire diagnostic vehicle data and over 79 kinds of vehicle for diagnostic or travel information such as speed, engine loading, engine R.P.M ...and more.



● Data provided by OBD-II

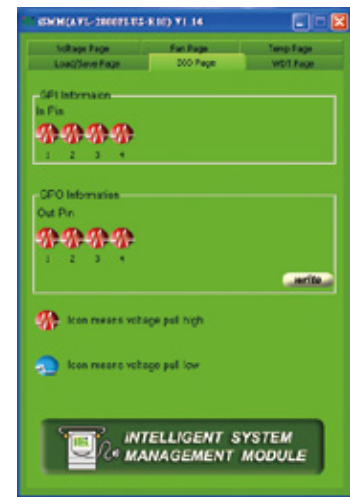

● Implement Digital I/O

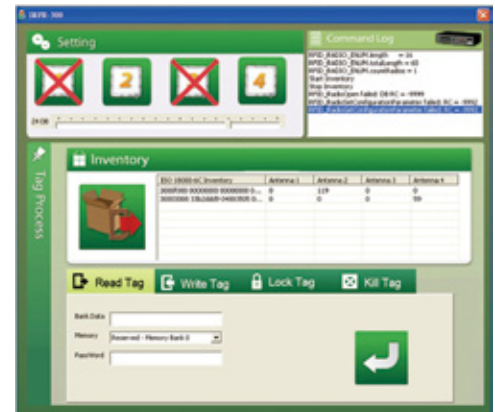

● UHF Module

### AVL-2000PLUS Dimensions (Unit : mm)

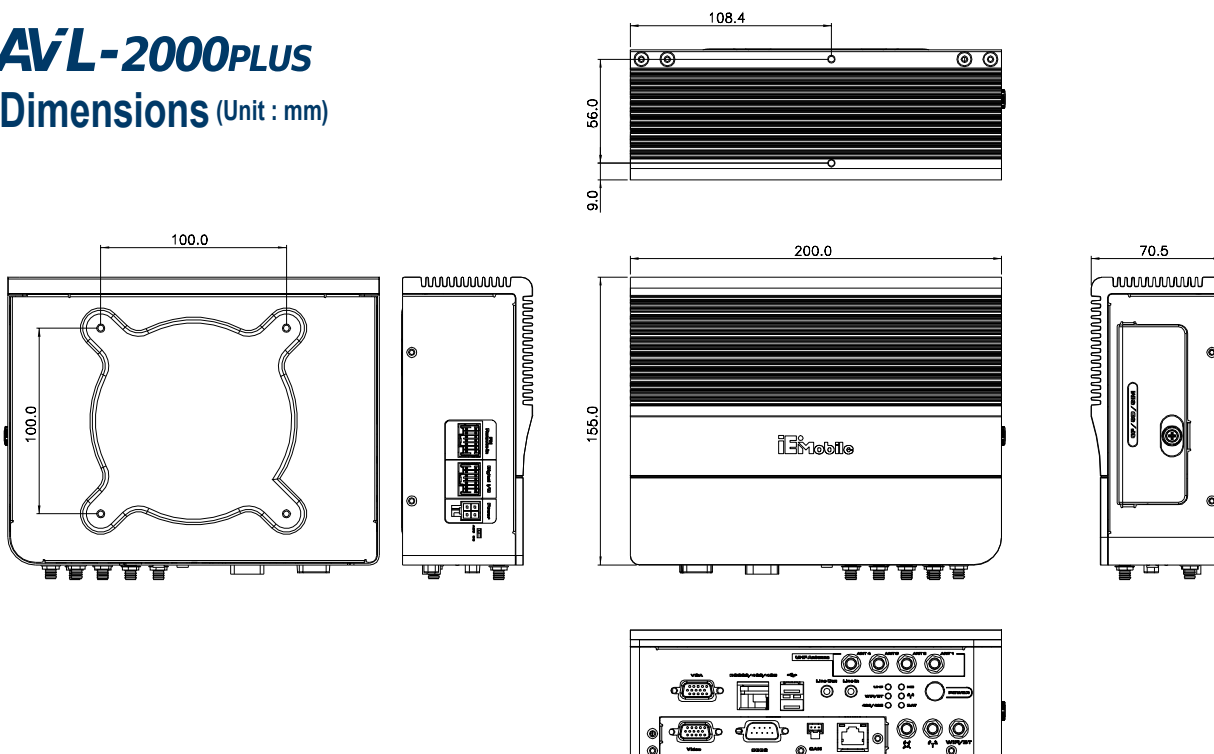

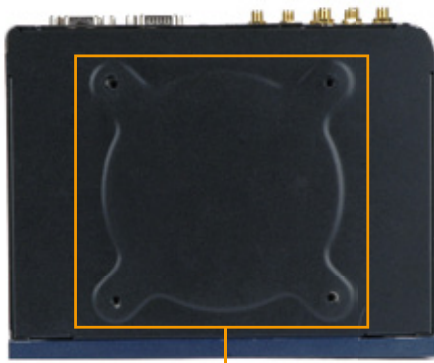

DIN Rail 100 Mount



Easy Access to CF, SD and SIM



FN Remote In  
Digital I/O 12 V DC IN

ACC/Manual Power Mode Switch

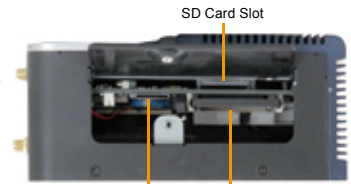
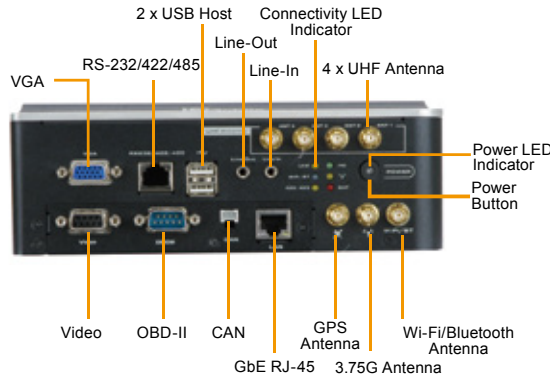

SIM Card Slot  
CF Card Slot

## Specifications

Model	AVL-2000PLUS	
System	CPU	Intel® Atom™ Z510 1.1 GHz
	Chipset	Intel® US15WP
	Operating System	Microsoft® Windows® XP Embedded
	Memory	1 GB DDR2 533 MHz On-board
	Storage	4GB CompactFlash® SD Card Slot
Communication	Wireless LAN	Wi-Fi® 802.11b/g
	Bluetooth	Bluetooth® V2.0+ EDR (Class 1)
	Modem	WCDMA/HSUPA
	GPS	GPS
Multimedia	Audio	1 x Line-in 1 x Line-out
Data Collection	RFID	ISO 18000-6C UHF RFID (Optional)
	Video Capturing	Video Input : 4 channels composite video(NTSC/PAL/SECAM) Frame rate : 4 channels with 120fps@D1 per channel(NTSC), 4 channels with 100fps@D1 per channel(PAL/SECAM)
LED Indicators & Buttons	Indicators	UHF/Wi-Fi®/Bluetooth®/ RS-422/485/HDD/3.75G/BAT/Power Status LED
	Buttons	Power Button
I/O Interface	USB	2 x USB 2.0
	Serial	1 x DB-9 OBD-II 1 x RJ-45 RS-232/422/485
	LAN	1 x 10/100/1000 Mbps GbE RJ-45
	VGA	1 x VGA
	CAN	1 x CAN 2.0b
	Digital I/O	4 Inputs / 4 Outputs
Power	Cigarette Lighter Power	Cigarette Lighter Power Cable DC 9~30V
	ACC Power	Manual power mode and ignition detection supported ACC power on/off mode with software configurable delay time
	Power Adapte	12V@3A@36W (Optional)
Environment	Operating Temperature	-30°C to +70°C
	Storage Temperature	-30°C to +80°C
	Humidity	5%~95% non-condensing
	Certification	CE/FCC/e-Mark
Physical Characteristics	Dimensions (LxWxH) (mm)	200 x 155 x 70
	Net Weight	1,978g

## Ordering Information

Part Number	Description
AVL-2000P-510/HU-R10	Vehicle PC Box with Intel® Atom™ Z510 1.1GHz CPU, 1GB SDRAM, 802.11 b/g Wireless, Bluetooth, Gobi2000 HSUPA, 4CH 120 FPS Video Capture, OBD-II, GPS with DR, RoHs
AVL-2000P-510/HU/FCC-R10	Vehicle PC Box with Intel® Atom™ Z510 1.1GHz CPU, 1GB SDRAM, 802.11 b/g Wireless, Bluetooth, Gobi2000 HSUPA, 4CH 120 FPS Video Capture, OBD-II, GPS with DR, UHF FCC, RoHs
AVL-2000P-510/HU/ETSI-R10	Vehicle PC Box with Intel® Atom™ Z510 1.1GHz CPU, 1GB SDRAM, 802.11 b/g Wireless, Bluetooth, Gobi2000 HSUPA, 4CH 120 FPS Video Capture, OBD-II, GPS with DR, UHF ETSI, RoHs
AVL-2000P-510/HW-R10	Vehicle PC Box with Intel® Atom™ Z510 1.1GHz CPU, 1GB SDRAM, 802.11 b/g Wireless, Bluetooth, HUAWEI EM770W HSUPA, 4CH 120 FPS Video Capture, OBD-II, GPS with DR, RoHs
AVL-2000P-510/HW/FCC-R10	Vehicle PC Box with Intel® Atom™ Z510 1.1GHz CPU, 1GB SDRAM, 802.11 b/g Wireless, Bluetooth, HUAWEI EM770W HSUPA, 4CH 120 FPS Video Capture, OBD-II, GPS with DR, UHF FCC, RoHs
AVL-2000P-510/HW/ETSI-R10	Vehicle PC Box with Intel® Atom™ Z510 1.1GHz CPU, 1GB SDRAM, 802.11 b/g Wireless, Bluetooth, HUAWEI EM770W HSUPA, 4CH 120 FPS Video Capture, OBD-II, GPS with DR, UHF ETSI, RoHs

## Support Function

Part Number	Wireless	Bluetooth	Video Capture	GPS	3.75G	UHF RFID
AVL-2000P-510/HU-R10	802.11 b/g	V2.0+EDR, Class 1	4CH 120 FPS	U-blox	Qualcomm Gobi2000	None
AVL-2000P-510/HU/FCC-R10	802.11 b/g	V2.0+EDR, Class 1	4CH 120 FPS	U-blox	Qualcomm Gobi2000	UHF FCC
AVL-2000P-510/HU/ETSI-R10	802.11 b/g	V2.0+EDR, Class 1	4CH 120 FPS	U-blox	HUAWEI EM770W	UHF ETSI
AVL-2000P-510/HW-R10	802.11 b/g	V2.0+EDR, Class 1	4CH 120 FPS	U-blox	HUAWEI EM770W	None
AVL-2000P-510/HW/FCC-R10	802.11 b/g	V2.0+EDR, Class 1	4CH 120 FPS	U-blox	Qualcomm Gobi2000	UHF FCC
AVL-2000P-510/HW/ETSI-R10	802.11 b/g	V2.0+EDR, Class 1	4CH 120 FPS	U-blox	HUAWEI EM770W	UHF ETSI

## Packing List

Item	Part Number	Q'ty
Cigarette Lighter Power Cable	32002-001800-100-RS	1
ACC Power Cable	32002-001900-100-RS	1
RS-232 Cable	32005-000200-200-RS	1
Capture Cable	32007-001400-100-RS	1
OBD-II Cable	32025-000300-100-RS	1
J1939 Cable	32025-000400-100-RS	1
Wi-Fi/BT Antenna	32505-000400-100-RS	1
GPS / 3.75G Integrate Antenna	32506-000100-100-RS	1
User's Manual CD-ROM	7B000-000568-RS	1
IEI One Key Recovery CD	IEI-7B000-000478-RS	1

## Optional Accessory List

Item	Part Number	Description
UHF RFID Antenna w/Cable	AVL-2000PLUS-FCC01-R10	PATCH ANTENNA 915MHz RFID CABLE 10000MM
	AVL-2000PLUS-ETSI01-R10	PATCH ANTENNA 867.5MHz RFID CABLE 10000MM
Power Adapter	63040-010036-000-RS	Adapter Power;FSP;FSP036-RAB;Active PFC;Vin:90~264VAC;36W;Dim:91.5*37.5*26.0mm;;Cable=1500mm;;Vout:12VDC;ATX 2*2 Pitch:4.2mm;RoHS



Power Adapter



ACC Power Cable



Capture Cable



Cigarette Lighter Power Cable



GPS / 3.75G Integrate Antenna



UHF RFID Cable



J1939 Cable



OBD-II Cable



RS-232 Cable



Wi-Fi/BT Antenna



UHF RFID Antenna